

THROUGH FRAME
INSTALLATION

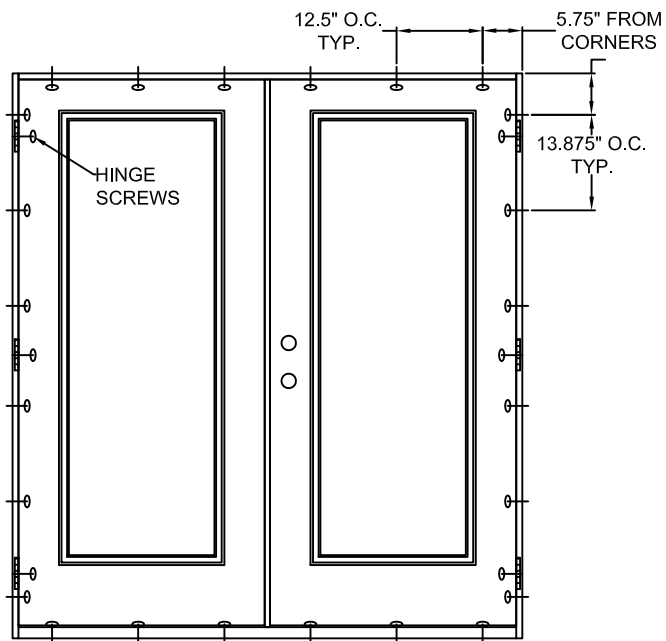

TYPICAL ELEVATION WITH FASTENER SPACING

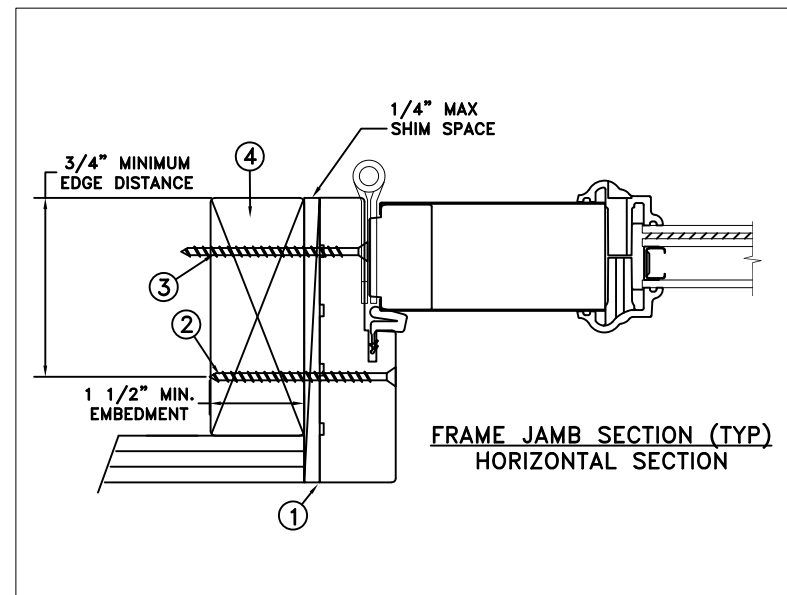
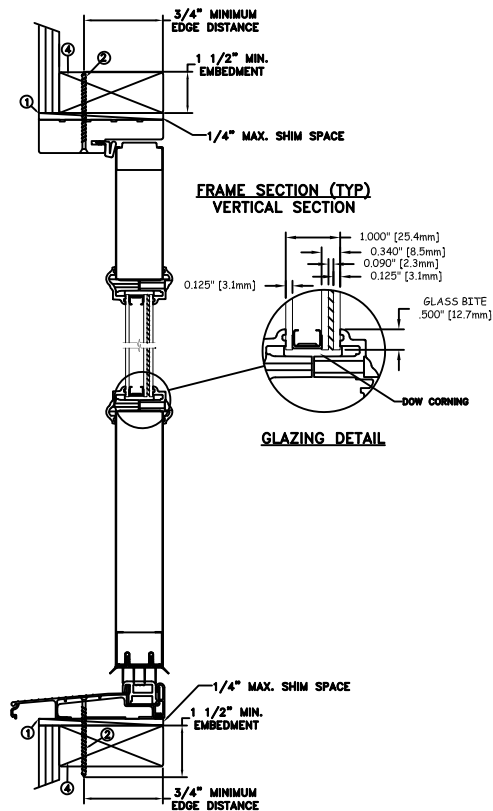

MAXIMUM FRAME	DP	IMPACT
74 x 82	+60/-65	YES

Installation Notes:

1. Seal flange/frame to substrate. Sill shall be set on a continuous serpentine bead of structural grade silicone caulk when no fastener is used to anchor the sill (typical).
2. Use #8 PH or greater fastener through the head & side jambs with sufficient length to penetrate a minimum of 1 1/2" into the wood framing. For 2x wood frame substrate (min. S.G. = 0.42)
3. Install corrosion resistant (2) - 1/4"x 3" Tapcon screws through each hinge into rough opening.
4. Host structure (wood buck, masonry, steel) to be designed and anchored to properly transfer all loads to the structure. The host structure is the responsibility of the architect or engineer of record for the project of installation.

General Notes:

1. The product shown herein is designed, tested and manufactured to comply with the wind load criteria of the adopted International Building Code (IBC), the International Residential Code (IRC), the current Florida Building Code (FBC) and the industry requirement for the stated conditions.
2. All glazing shall conform to ASTM E1300.
3. At minimum, glazing shall be 3.1mm annealed - 13.7mm airspace - 3.1mm annealed - 2.3mm PVB Interlayer by Kurraray - 3.1mm annealed glass.
4. Use structural or composite shims where required.

This schedule addresses only the fasteners required to anchor the unit to achieve the rated design pressure and impact performance (where applicable) up to the size limitations noted. It is not intended as a guide to the installation process and does not address the sealing consideration that may arise in different wall conditions. For the complete installation procedure, see the instructions packaged with the unit or go to www.jeld-wen.com.

DISCLAIMER:

This drawing and its contents are confidential and are not to be reproduced or copied in whole or in part or used or disclosed to others except as authorized by JELD-WEN Inc.



This item has been digitally signed and sealed by Michael D. Stremmel, PE on the date adjacent to the seal. Printed copies of this document are not considered signed and sealed and the signature must be verified on any electronic copies.

Michael D. Stremmel
2024.03.22 06:56:38 -0400'

MICHAEL D. STREMMEL, P.E.
Florida P.E. No. 65868, REG. No. 37122
1410 Eden Road
York, PA. 17406
(717) 916-6300

DATE: 09/15/2023		3737 LAKEPORT BLVD. KLAMATH FALLS OR, 97601 PHONE: (800) 535-3936
DRAWN BY: M.HAM		SCALE: NTS
CHECKED BY: D.Vezo	TITLE: Contours Steel Wood Edge Inswing Glazed XX	
APPROVED BY: D.Vezo	RECORD No.:	
	D1000368	
REPORT No.:	CAD DWG. No.:	REV: C SHEET 1 of 10
NCTL-210-3195-1	-	

MASONRY STRAP INSTALLATION

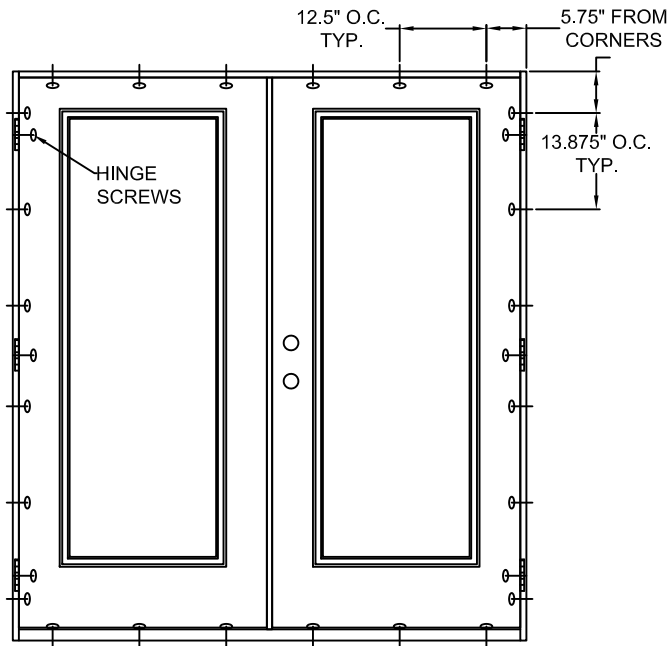

TYPICAL ELEVATION WITH FASTENER SPACING

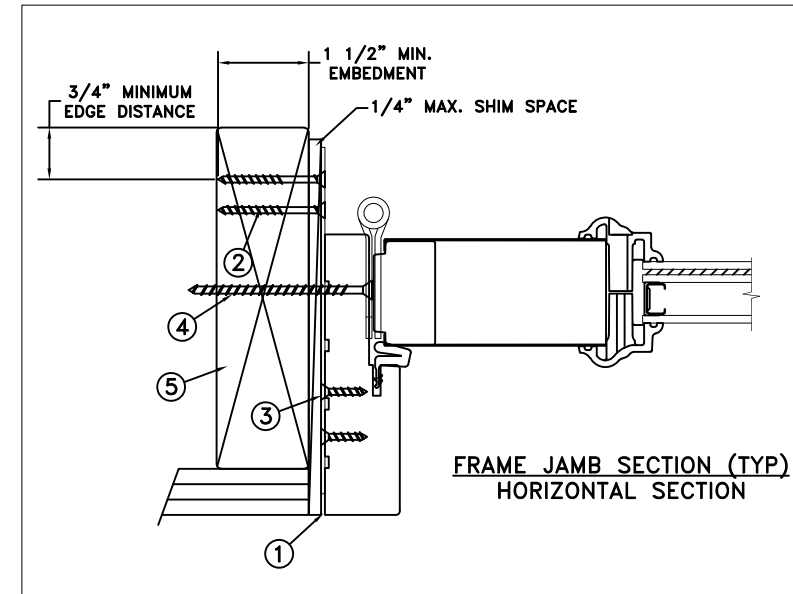
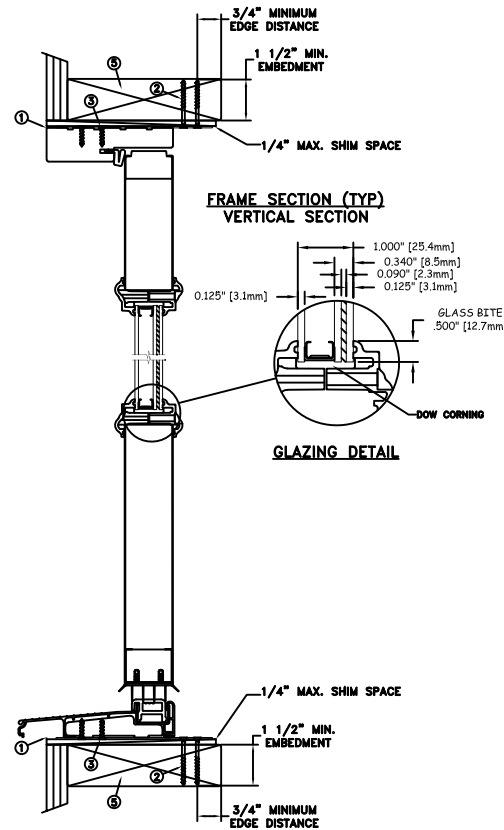

MAXIMUM FRAME	DP	IMPACT
74 x 82	+60/-65	YES

Installation Notes:

1. Seal flange/frame to substrate. Sill shall be set on a continuous serpentine bead of structural grade silicone caulk when no fastener is used to anchor the sill (typical).
2. Use 2 - #8 PFH or larger fasteners through masonry strap with sufficient length to penetrate a minimum of 1 1/2" into the buck. For 2x wood frame substrate (min. S.G. = 0.42).
3. Use 2 - #8 PFH or larger fasteners through masonry strap into jamb without penetrating through the jamb into product causing visibility or collateral damage to product.
4. Install corrosion resistant (2) - 1/4"x 3" Tapcon screws through each hinge into rough opening.
5. Host structure (wood buck, masonry, steel) to be designed and anchored to properly transfer all loads to the structure. The host structure is the responsibility of the architect or engineer of record for the project of installation.

General Notes:

1. The product shown herein is designed, tested and manufactured to comply with the wind load criteria of the adopted International Building Code (IBC), the International Residential Code (IRC), the current Florida Building Code (FBC) and the industry requirement for the stated conditions.
2. All glazing shall conform to ASTM E1300.
3. At minimum, glazing shall be 3.1mm annealed - 13.7mm airspace - 3.1mm annealed - 2.3mm PVB Interlayer by Kurraray - 3.1mm annealed glass.
4. Use structural or composite shims where required.
5. Masonry strap specifications: 20 Ga. galvanized steel, .036" min. thickness x 1.5" min. width.

This schedule addresses only the fasteners required to anchor the unit to achieve the rated design pressure and impact performance (where applicable) up to the size limitations noted. It is not intended as a guide to the installation process and does not address the sealing consideration that may arise in different wall conditions. For the complete installation procedure, see the instructions packaged with the unit or go to www.jeld-wen.com.

DISCLAIMER:

This drawing and its contents are confidential and are not to be reproduced or copied in whole or in part or used or disclosed to others except as authorized by JELD-WEN Inc.



Michael D. Stremmel
2024.03.22 06:56:38 -0400'

MICHAEL D. STREMMEL, P.E.
Florida P.E. No. 65868, REG. No. 37122
1410 Eden Road
York, PA. 17406
(717) 916-6300

This item has been digitally signed and sealed by Michael D. Stremmel, PE on the date adjacent to the seal. Printed copies of this document are not considered signed and sealed and the signature must be verified on any electronic copies.

DATE: 09/15/2023	3737 LAKEPORT BLVD. KLAMATH FALLS OR, 97601 PHONE: (800) 535-3936
DRAWN BY: M.HAM	SCALE: NTS
CHECKED BY: D.Vezo	TITLE: Contours Steel Wood Edge Inswing Glazed XX
APPROVED BY: D.Vezo	
RECORD No.: D1000368	
REPORT No.: NCTL-210-3195-1	CAD DWG. No.: -
	REV: C SHEET 2 of 10

CONCRETE/MASONRY
INSTALLATION

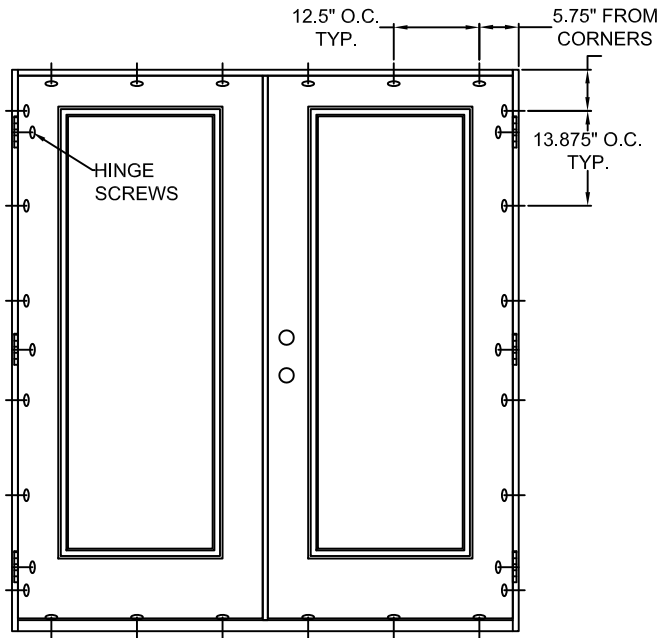

TYPICAL ELEVATION WITH FASTENER SPACING

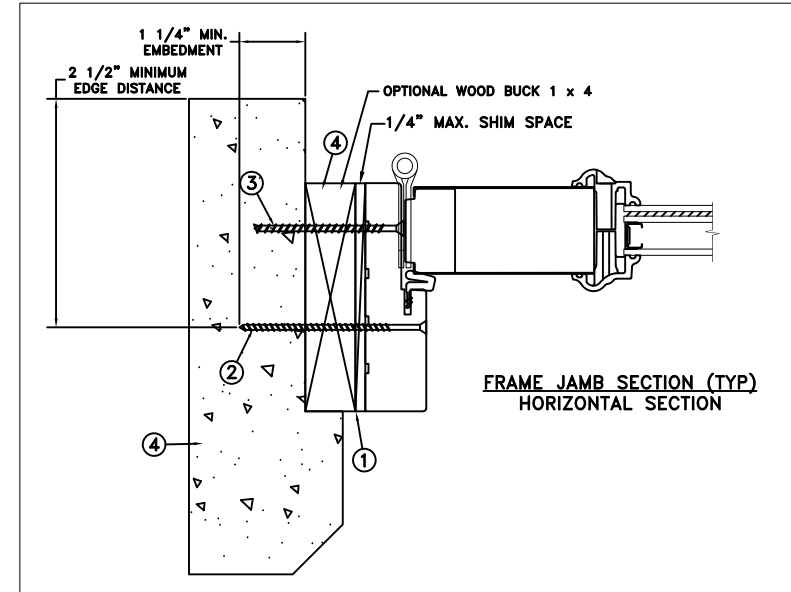
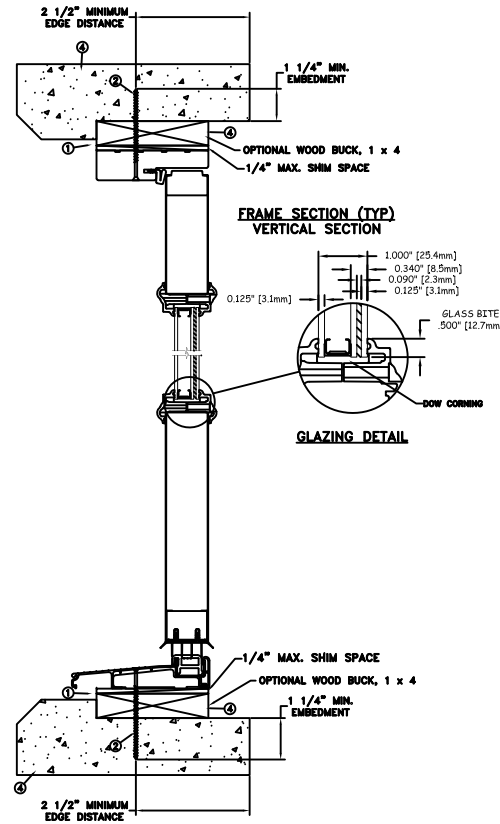

MAXIMUM FRAME	DP	IMPACT
74 x 82	+60/-65	YES

Installation Notes:

1. Seal flange/frame to substrate. Sill shall be set on a continuous serpentine bead of structural grade silicone caulk when no fastener is used to anchor the sill (typical).
2. Use 3/16" tapcon or equivalent fasteners through frame with sufficient length to penetrate a minimum of 1 1/4" into concrete or masonry at each location with a 2 1/2" min. from edge distance. For concrete (min. fc = 3000 psi) or masonry substrate (CMU shall adhere to ASTM C90).
3. Install corrosion resistant (2) - 1/4"x 3" Tapcon screws through each hinge into rough opening.
4. Host structure (wood buck, masonry, steel) to be designed and anchored to properly transfer all loads to the structure. The host structure is the responsibility of the architect or engineer of record for the project of installation.

General Notes:

1. The product shown herein is designed, tested and manufactured to comply with the wind load criteria of the adopted International Building Code (IBC), the International Residential Code (IRC), the current Florida Building Code (FBC) and the industry requirement for the stated conditions.
2. All glazing shall conform to ASTM E1300.
3. At minimum, glazing shall be 3.1mm annealed - 13.7mm airspace - 3.1mm annealed - 2.3mm PVB Interlayer by Kurraray - 3.1mm annealed glass.
4. Use structural or composite shims where required.

This schedule addresses only the fasteners required to anchor the unit to achieve the rated design pressure and impact performance (where applicable) up to the size limitations noted. It is not intended as a guide to the installation process and does not address the sealing consideration that may arise in different wall conditions. For the complete installation procedure, see the instructions packaged with the unit or go to www.jeld-wen.com.

DISCLAIMER:

This drawing and its contents are confidential and are not to be reproduced or copied in whole or in part or used or disclosed to others except as authorized by JELD-WEN Inc.



Michael D. Stremmel
2024.03.22 06:56:38 -0400'

MICHAEL D. STREMMEL, P.E.
Florida P.E. No. 65868, REG. No. 37122
1410 Eden Road
York, PA. 17406
(717) 916-6300

This item has been digitally signed and sealed by Michael D. Stremmel, PE on the date adjacent to the seal. Printed copies of this document are not considered signed and sealed and the signature must be verified on any electronic copies.

DATE: 09/15/2023	3737 LAKEPORT BLVD. KLAMATH FALLS OR, 97601 PHONE: (800) 535-3936
DRAWN BY: M.HAM	SCALE: NTS
CHECKED BY: D.Vezo	TITLE: Contours Steel Wood Edge Inswing Glazed XX
APPROVED BY: D.Vezo	
RECORD No.: D1000368	
REPORT No.: NCTL-210-3195-1	CAD DWG. No.: —
	REV: C SHEET 3 of 10

CONCRETE/MASONRY
INSTALLATION

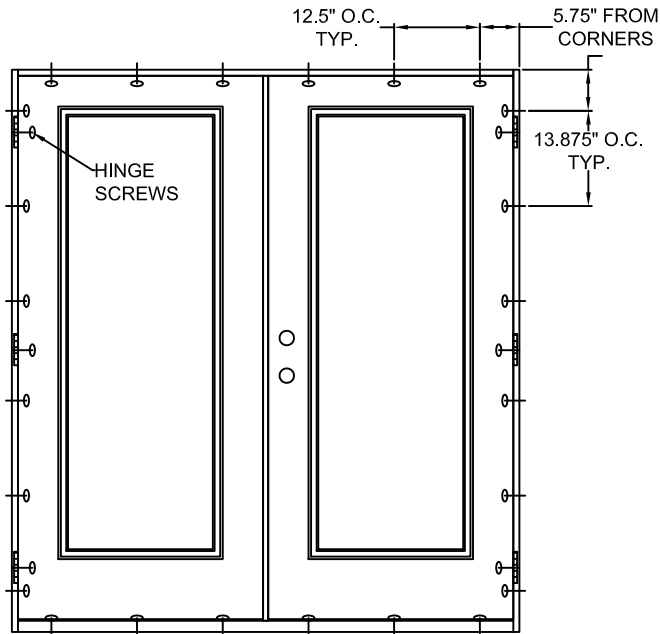

TYPICAL ELEVATION WITH FASTENER SPACING

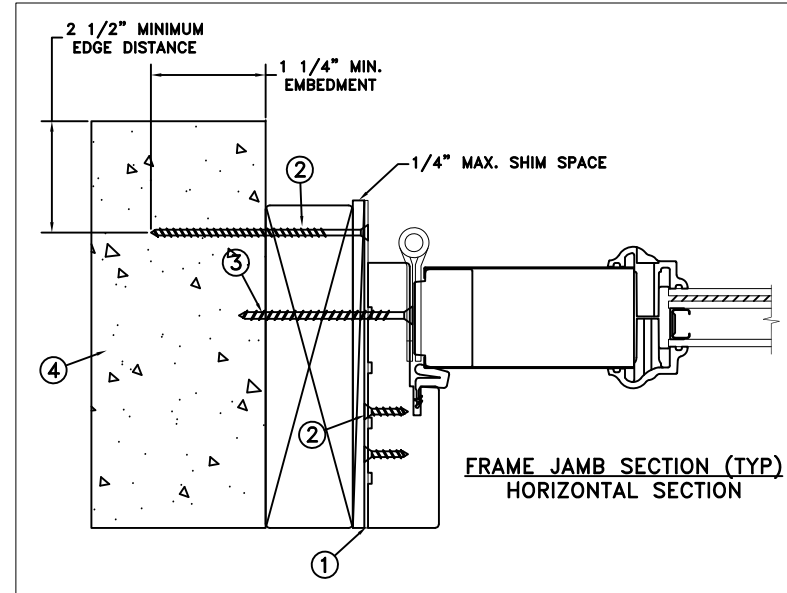
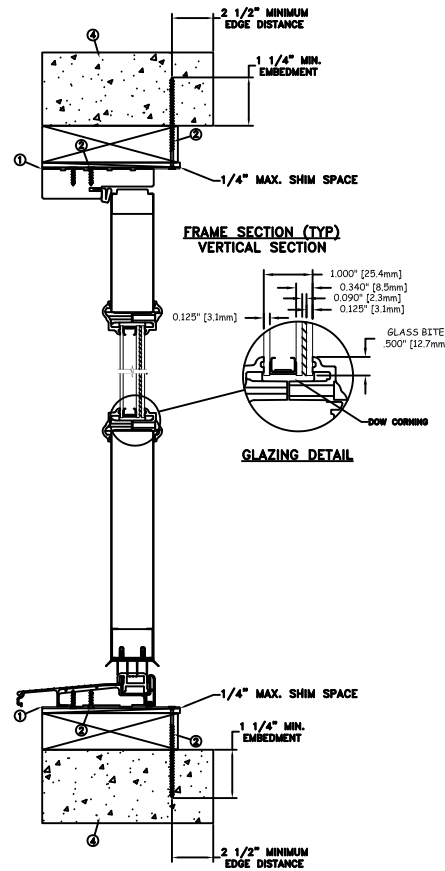

MAXIMUM FRAME	DP	IMPACT
74 x 82	+60/-65	YES

Installation Notes:

1. Seal flange/frame to substrate. Sill shall be set on a continuous serpentine bead of structural grade silicone caulk when no fastener is used to anchor the sill (typical).
2. Use (1) - 1/4" Tapcon or equivalent fasteners through strap with sufficient length to penetrate a minimum of 1 1/4" into concrete or masonry at each location with a 2 1/2" min. from edge distance. Use (2) - #8 PFH fasteners through masonry strap into frame. For concrete (min. fc = 3000 psi) or masonry substrate (CMU shall adhere to ASTM C90).
3. Install corrosion resistant (2) - 1/4"x 3" Tapcon screws through each hinge into rough opening.
4. Host structure (wood buck, masonry, steel) to be designed and anchored to properly transfer all loads to the structure. The host structure is the responsibility of the architect or engineer of record for the project of installation.

General Notes:

1. The product shown herein is designed, tested and manufactured to comply with the wind load criteria of the adopted International Building Code (IBC), the International Residential Code (IRC), the current Florida Building Code (FBC) and the industry requirement for the stated conditions.
2. All glazing shall conform to ASTM E1300.
3. At minimum, glazing shall be 3.1mm annealed - 13.7mm airspace - 3.1mm annealed - 2.3mm PVB Interlayer by Kurraray - 3.1mm annealed glass.
4. Use structural or composite shims where required.
5. Masonry strap specifications: 20 Ga. galvanized steel, .036" min. thickness x 1.5" min. width.

This schedule addresses only the fasteners required to anchor the unit to achieve the rated design pressure and impact performance (where applicable) up to the size limitations noted. It is not intended as a guide to the installation process and does not address the sealing consideration that may arise in different wall conditions. For the complete installation procedure, see the instructions packaged with the unit or go to www.jeld-wen.com.

DISCLAIMER:

This drawing and its contents are confidential and are not to be reproduced or copied in whole or in part or used or disclosed to others except as authorized by JELD-WEN Inc.



Michael D. Stremmel
2024.03.22 06:56:38 -0400'

MICHAEL D. STREMMEL, P.E.
Florida P.E. No. 65868, REG. No. 37122
1410 Eden Road
York, PA. 17406
(717) 916-6300

This item has been digitally signed and sealed by Michael D. Stremmel, PE on the date adjacent to the seal. Printed copies of this document are not considered signed and sealed and the signature must be verified on any electronic copies.

DATE: 09/15/2023	JELD-WEN 3737 LAKEPORT BLVD. KLAMATH FALLS OR, 97601 PHONE: (800) 535-3936		
DRAWN BY: M.HAM			
CHECKED BY: D.Vezo	TITLE: Contours Steel Wood Edge Inswing Glazed XX		
APPROVED BY: D.Vezo			
RECORD No.:			
REPORT No.:	CAD DWG. No.:	REV:	SHEET
NCTL-210-3195-1	-	C	4 of 10

MASONRY STRAP INSTALLATION

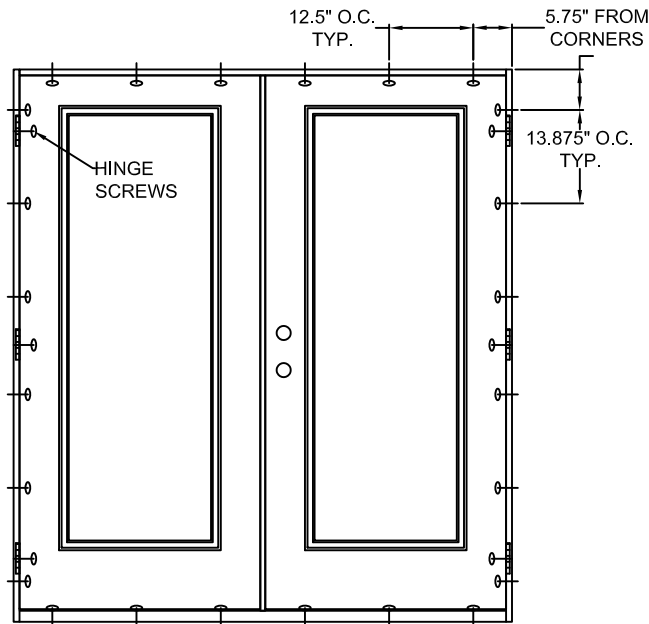

TYPICAL ELEVATION WITH FASTENER SPACING

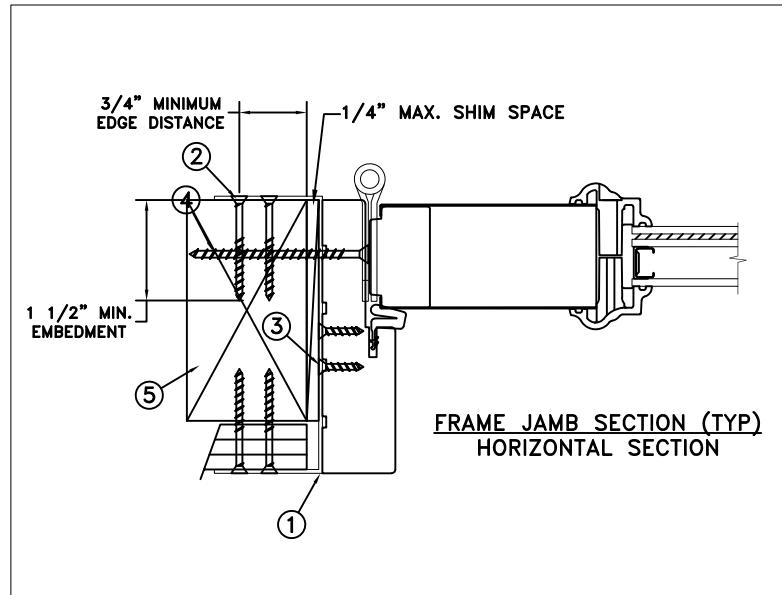
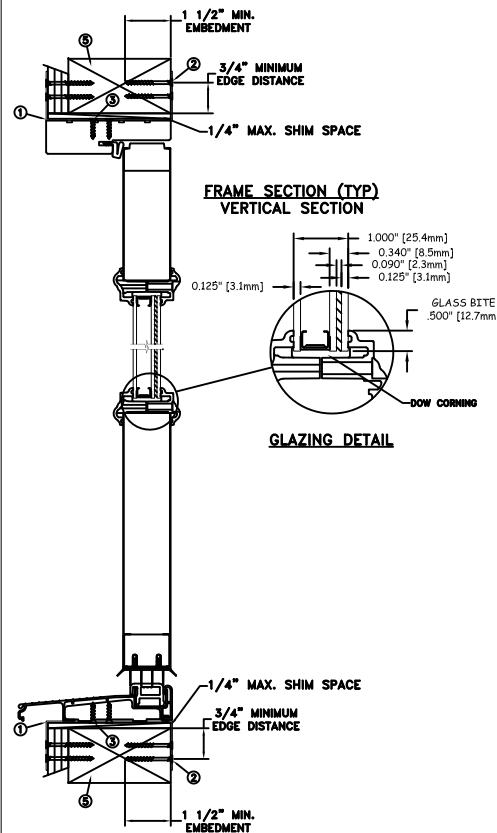

MAXIMUM FRAME	DP	IMPACT
74 x 82	+60/-65	YES

Installation Notes:

1. Seal flange/frame to substrate. Sill shall be set on a continuous serpentine bead of structural grade silicone caulk when no fastener is used to anchor the sill (typical).
2. Use min. 2 - #8 PFH or larger fasteners through masonry strap with sufficient length to penetrate a minimum of 1 1/2" into the buck. Bend straps around both sides of the buck. For 2x wood frame substrate (min. S.G. = 0.42).
3. Use min. 2 - #8 PFH or larger fasteners through masonry strap into jamb without penetrating through the jamb into product causing visibility or collateral damage to product.
4. Install corrosion resistant (2)- 1/4"x 3" Tapcon screws through each hinge into rough opening.
5. Host structure (wood buck, masonry, steel) to be designed and anchored to properly transfer all loads to the structure. The host structure is the responsibility of the architect or engineer of record for the project of installation.

General Notes:

1. The product shown herein is designed, tested and manufactured to comply with the wind load criteria of the adopted International Building Code (IBC), the International Residential Code (IRC), the current Florida Building Code (FBC) and the industry requirement for the stated conditions.
2. All glazing shall conform to ASTM E1300.
3. At minimum, glazing shall be 3.1mm annealed - 13.7mm airspace - 3.1mm annealed - 2.3mm PVB Interlayer by Kurraray - 3.1mm annealed glass.
4. Use structural or composite shims where required.
5. Masonry strap specifications: 20 Ga. galvanized steel, .036" min. thickness x 1.5" min. width.

This schedule addresses only the fasteners required to anchor the unit to achieve the rated design pressure and impact performance (where applicable) up to the size limitations noted. It is not intended as a guide to the installation process and does not address the sealing consideration that may arise in different wall conditions. For the complete installation procedure, see the instructions packaged with the unit or go to www.jeld-wen.com.

DISCLAIMER:

This drawing and its contents are confidential and are not to be reproduced or copied in whole or in part or used or disclosed to others except as authorized by JELD-WEN Inc.



Michael D. Stremmel
2024.03.22 06:56:38 -0400'

MICHAEL D. STREMMEL, P.E.
Florida P.E. No. 65868, REG. No. 37122
1410 Eden Road
York, PA 17406
(717) 916-6300

This item has been digitally signed and sealed by Michael D. Stremmel, PE on the date adjacent to the seal. Printed copies of this document are not considered signed and sealed and the signature must be verified on any electronic copies.

DATE: 09/15/2023	3737 LAKEPORT BLVD. KLAMATH FALLS OR, 97601 PHONE: (800) 535-3936
DRAWN BY: M.HAM	SCALE: NTS
CHECKED BY: D.Vezo	TITLE: Contours Steel Wood Edge Inswing Glazed XX
APPROVED BY: D.Vezo	
REPORT No.: NCTL-210-3195-1	RECORD No.: D1000368
CAD DWG. No.: -	REV: C SHEET 5 of 10

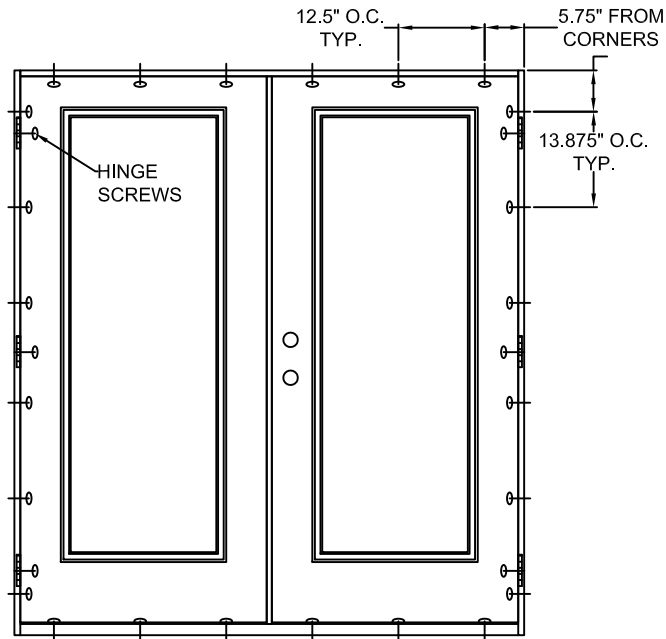

TYPICAL ELEVATION WITH FASTENER SPACING

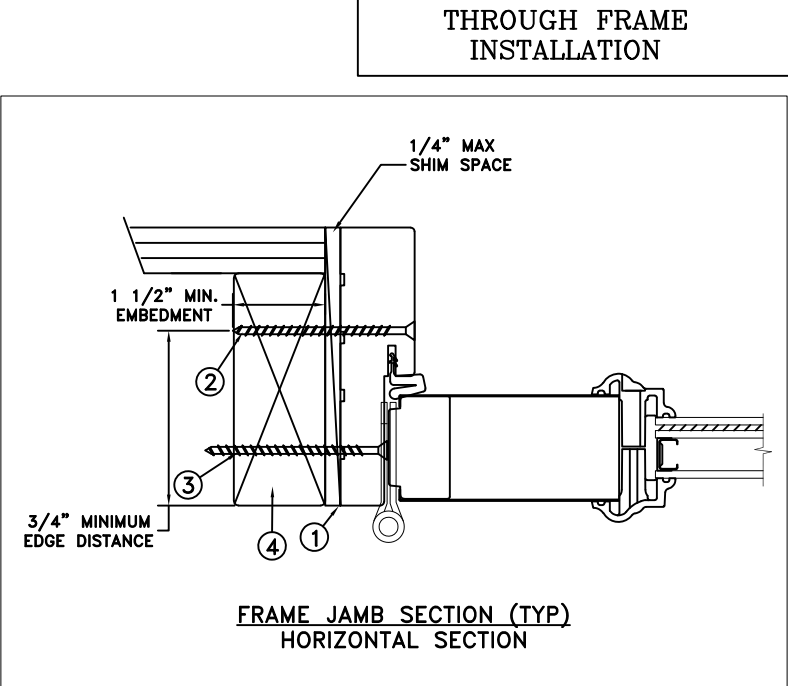
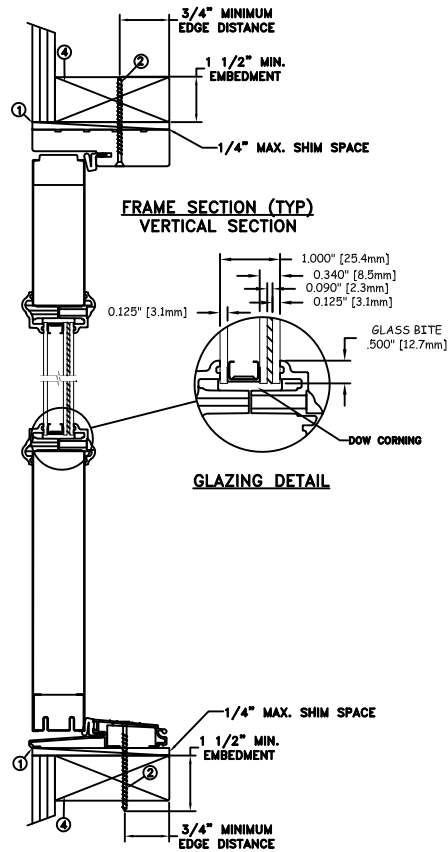

MAXIMUM FRAME	DP	IMPACT
74 x 82	+65/-60	YES

Installation Notes:

1. Seal flange/frame to substrate. Sill shall be set on a continuous serpentine bead of structural grade silicone caulk when no fastener is used to anchor the sill (typical).
2. Use #8 PH or greater fastener through the head & side jambs with sufficient length to penetrate a minimum of 1 1/2" into the wood framing. For 2x wood frame substrate (min. S.G. = 0.42)
3. Install corrosion resistant (2) - 1/4"x 3" Tapcon screws through each hinge into rough opening.
4. Host structure (wood buck, masonry, steel) to be designed and anchored to properly transfer all loads to the structure. The host structure is the responsibility of the architect or engineer of record for the project of installation.

General Notes:

1. The product shown herein is designed, tested and manufactured to comply with the wind load criteria of the adopted International Building Code (IBC), the International Residential Code (IRC), the current Florida Building Code (FBC) and the industry requirement for the stated conditions.
2. All glazing shall conform to ASTM E1300.
3. At minimum, glazing shall be 3.1mm annealed - 13.7mm airspace - 3.1mm annealed - 2.3mm PVB Interlayer by Kurraray - 3.1mm annealed glass.
4. Use structural or composite shims where required.

This schedule addresses only the fasteners required to anchor the unit to achieve the rated design pressure and impact performance (where applicable) up to the size limitations noted. It is not intended as a guide to the installation process and does not address the sealing consideration that may arise in different wall conditions. For the complete installation procedure, see the instructions packaged with the unit or go to www.jeld-wen.com.

DISCLAIMER:
This drawing and its contents are confidential and are not to be reproduced or copied in whole or in part or used or disclosed to others except as authorized by JELD-WEN Inc.



This item has been digitally signed and sealed by Michael D. Stremmel, PE on the date adjacent to the seal. Printed copies of this document are not considered signed and sealed and the signature must be verified on any electronic copies.

Michael D. Stremmel
2024.03.22 06:56:38 -0400'

MICHAEL D. STREMMEL, P.E.
Florida P.E. No. 65868, REG. No. 37122
1410 Eden Road
York, PA. 17406
(717) 916-6300

DATE: 09/15/2023		3737 LAKEPORT BLVD. KLAMATH FALLS OR, 97601 PHONE: (800) 535-3936
DRAWN BY: M.HAM		SCALE: NTS
CHECKED BY: D.Vezo	TITLE: Contours Steel Wood Edge Outswing Glazed XX	
APPROVED BY: D.Vezo	RECORD No.:	
	D1000368	
REPORT No.:	CAD DWG. No.:	REV: C SHEET 6 of 10
NCTL-210-3195-1	-	

MASONRY STRAP
INSTALLATION

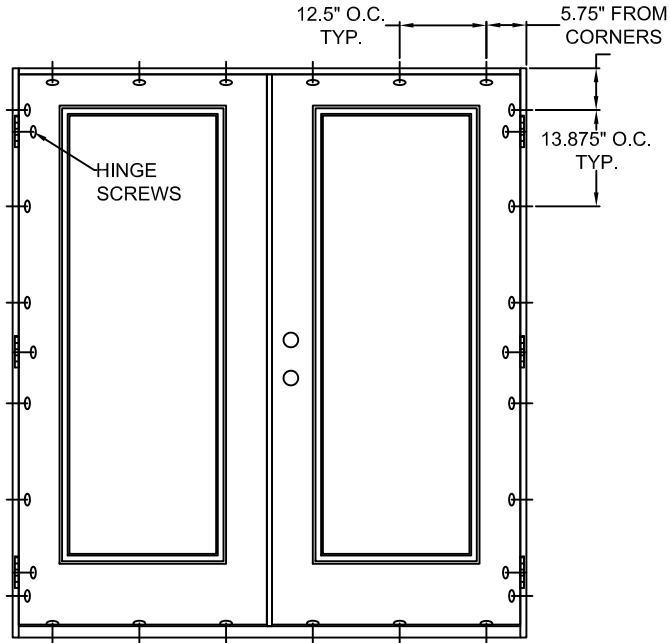

TYPICAL ELEVATION WITH FASTENER SPACING

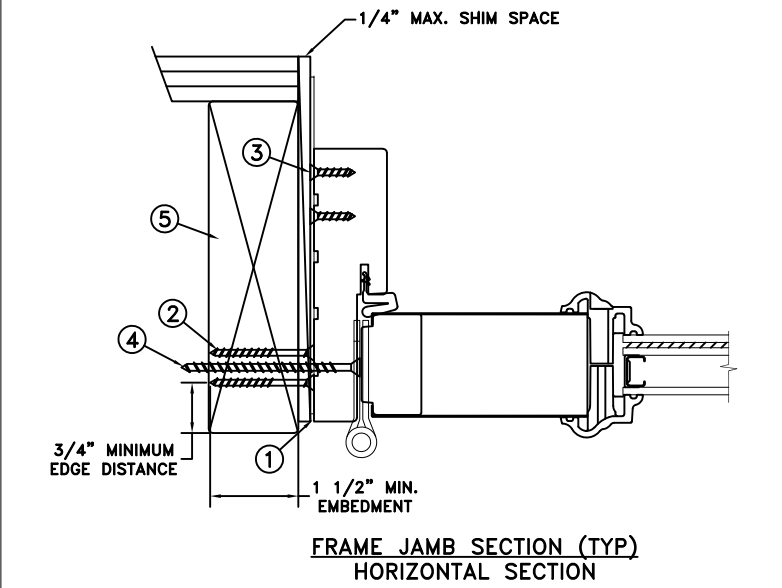
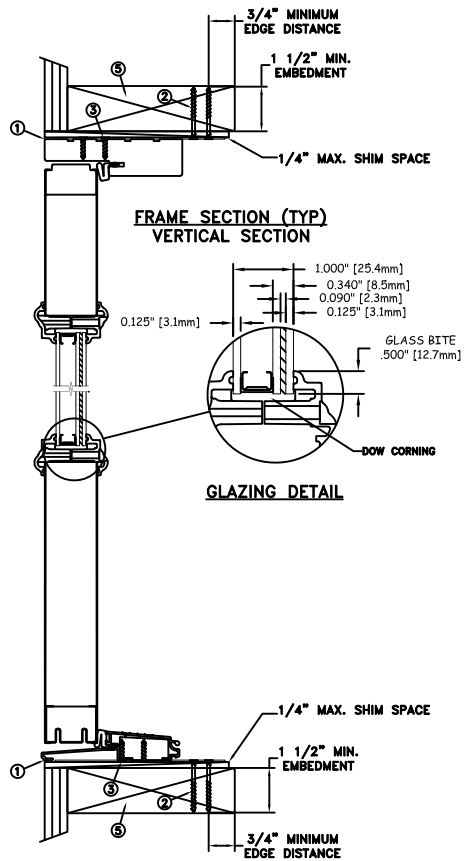

MAXIMUM FRAME	DP	IMPACT
74 x 82	+65/-60	YES

Installation Notes:

1. Seal flange/frame to substrate. Sill shall be set on a continuous serpentine bead of structural grade silicone caulk when no fastener is used to anchor the sill (typical).
2. Use 2 - #8 PFH or larger fasteners through masonry strap with sufficient length to penetrate a minimum of 1 1/2" into the buck. For 2x wood frame substrate (min. S.G. = 0.42).
3. Use 2 - #8 PFH or larger fasteners through masonry strap into jamb without penetrating through the jamb into product causing visibility or collateral damage to product.
4. Install corrosion resistant (2) - 1/4"x 3" Tapcon screws through each hinge into rough opening.
5. Host structure (wood buck, masonry, steel) to be designed and anchored to properly transfer all loads to the structure. The host structure is the responsibility of the architect or engineer of record for the project of installation.

General Notes:

1. The product shown herein is designed, tested and manufactured to comply with the wind load criteria of the adopted International Building Code (IBC), the International Residential Code (IRC), the current Florida Building Code (FBC) and the industry requirement for the stated conditions.
2. All glazing shall conform to ASTM E1300.
3. At minimum, glazing shall be 3.1mm annealed - 13.7mm airspace - 3.1mm annealed - 2.3mm PVB Interlayer by Kurraray - 3.1mm annealed glass.
4. Use structural or composite shims where required.
5. Masonry strap specifications: 20 Ga. galvanized steel, .036" min. thickness x 1.5" min. width.

This schedule addresses only the fasteners required to anchor the unit to achieve the rated design pressure and impact performance (where applicable) up to the size limitations noted. It is not intended as a guide to the installation process and does not address the sealing consideration that may arise in different wall conditions. For the complete installation procedure, see the instructions packaged with the unit or go to www.jeld-wen.com.

DISCLAIMER:
This drawing and its contents are confidential and are not to be reproduced or copied in whole or in part or used or disclosed to others except as authorized by JELD-WEN Inc.

This item has been digitally signed and sealed by Michael D. Stremmel, PE on the date adjacent to the seal. Printed copies of this document are not considered signed and sealed and the signature must be verified on any electronic copies.

Michael D. Stremmel
2024.03.22 06:56:38 -0400'

MICHAEL D. STREMMEL, P.E.
Florida P.E. No. 65868, REG. No. 37122
1410 Eden Road
York, PA. 17406
(717) 916-6300

DATE: 09/15/2023	<p>3737 LAKEPORT BLVD. KLAMATH FALLS OR, 97601 PHONE: (800) 535-3936</p>		
DRAWN BY: M.HAM			
CHECKED BY: D.Vezo	<p>Contours Steel Wood Edge Outswing Glazed XX</p>		
APPROVED BY: D.Vezo			
RECORD No.:			
REPORT No.:	CAD DWG. No.:	REV:	SHEET
NCTL-210-3195-1	-	C	7 of 10

CONCRETE/MASONRY
INSTALLATION

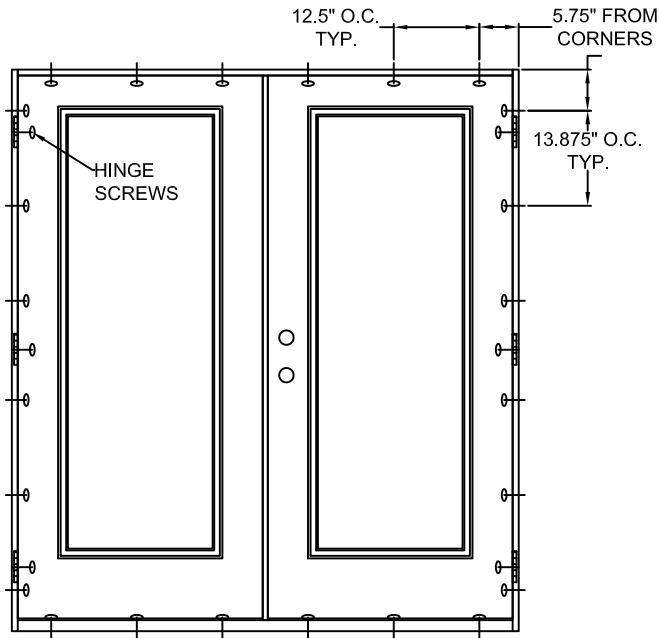

TYPICAL ELEVATION WITH FASTENER SPACING

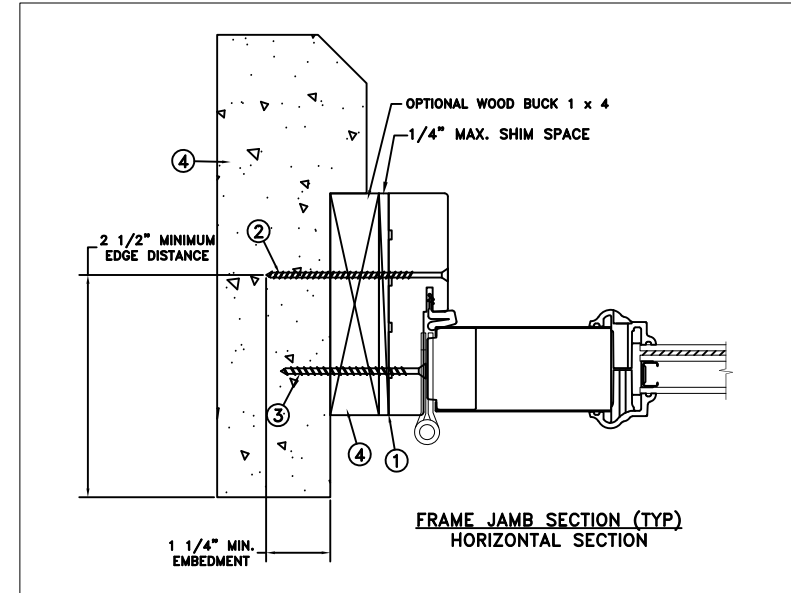
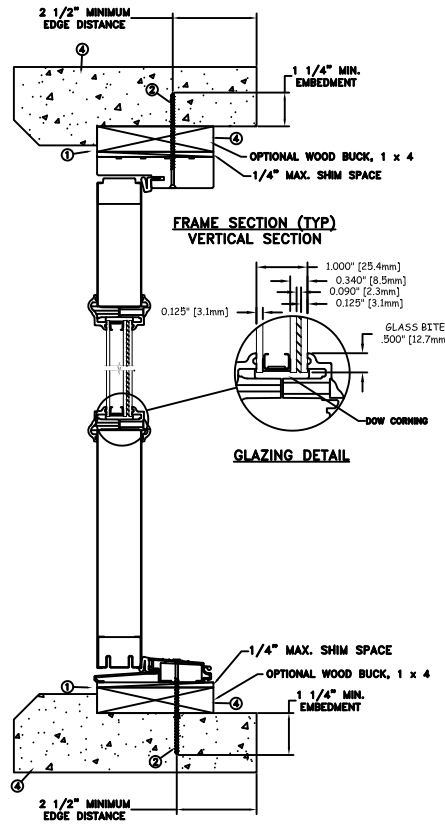

MAXIMUM FRAME	DP	IMPACT
74 x 82	+65/-60	YES

Installation Notes:

1. Seal flange/frame to substrate. Sill shall be set on a continuous serpentine bead of structural grade silicone caulk when no fastener is used to anchor the sill (typical).
2. Use 3/16" tapcon or equivalent fasteners through frame with sufficient length to penetrate a minimum of 1 1/4" into concrete or masonry at each location with a 2 1/2" min. from edge distance. For concrete (min. fc = 3000 psi) or masonry substrate (CMU shall adhere to ASTM C90).
3. Install corrosion resistant (2) - 1/4"x 3" Tapcon screws through each hinge into rough opening.
4. Host structure (wood buck, masonry, steel) to be designed and anchored to properly transfer all loads to the structure. The host structure is the responsibility of the architect or engineer of record for the project of installation.

General Notes:

1. The product shown herein is designed, tested and manufactured to comply with the wind load criteria of the adopted International Building Code (IBC), the International Residential Code (IRC), the current Florida Building Code (FBC) and the industry requirement for the stated conditions.
2. All glazing shall conform to ASTM E1300.
3. At minimum, glazing shall be 3.1mm annealed - 13.7mm airspace - 3.1mm annealed - 2.3mm PVB Interlayer by Kurraray - 3.1mm annealed glass.
4. Use structural or composite shims where required.

This schedule addresses only the fasteners required to anchor the unit to achieve the rated design pressure and impact performance (where applicable) up to the size limitations noted. It is not intended as a guide to the installation process and does not address the sealing consideration that may arise in different wall conditions. For the complete installation procedure, see the instructions packaged with the unit or go to www.jeld-wen.com.

DISCLAIMER:

This drawing and its contents are confidential and are not to be reproduced or copied in whole or in part or used or disclosed to others except as authorized by JELD-WEN Inc.



This item has been digitally signed and sealed by Michael D. Stremmel, PE on the date adjacent to the seal. Printed copies of this document are not considered signed and sealed and the signature must be verified on any electronic copies.

Michael D. Stremmel
2024.03.22 06:56:38 -0400'

MICHAEL D. STREMMEL, P.E.
Florida P.E. No. 65868, REG. No. 37122
1410 Eden Road
York, PA. 17406
(717) 916-6300

DATE: 09/15/2023	<p>3737 LAKEPORT BLVD. KLAMATH FALLS OR, 97601 PHONE: (800) 535-3936</p>
DRAWN BY: M.HAM	
CHECKED BY: D.Vezo	SCALE: NTS
APPROVED BY: D.Vezo	TITLE: Contours Steel Wood Edge Outswing Glazed XX
RECORD No.: D1000368	
REPORT No.: NCTL-210-3195-1	CAD DWG. No.: -
	REV: C
	SHEET 8 of 10

CONCRETE/MASONRY
INSTALLATION

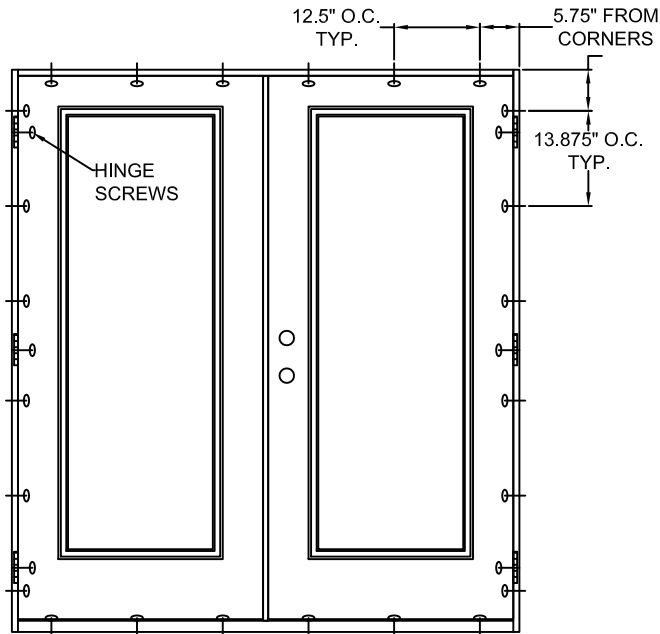

TYPICAL ELEVATION WITH FASTENER SPACING

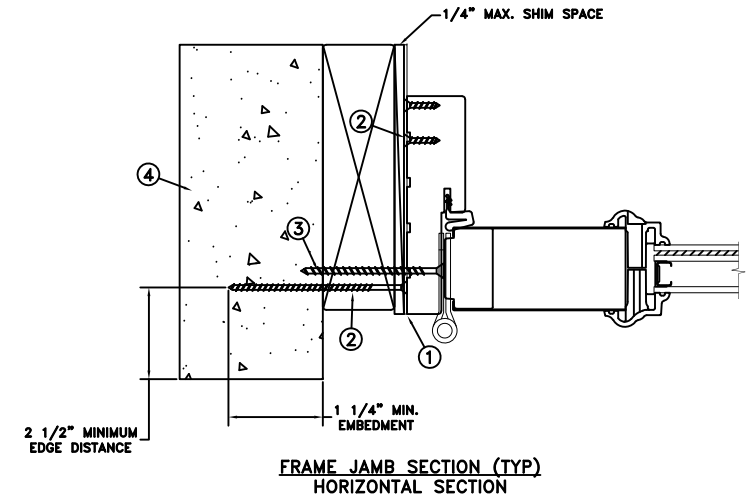
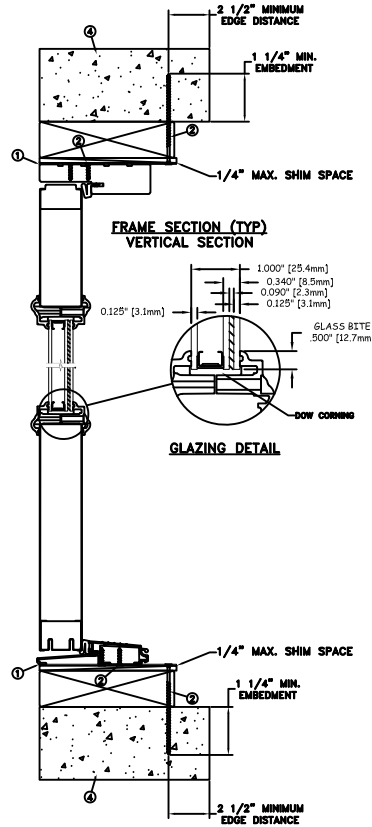

MAXIMUM FRAME	DP	IMPACT
74 x 82	+65/-60	YES

Installation Notes:

1. Seal flange/frame to substrate. Sill shall be set on a continuous serpentine bead of structural grade silicone caulk when no fastener is used to anchor the sill (typical).
2. Use (1) - 1/4" Tapcon or equivalent fasteners through strap with sufficient length to penetrate a minimum of 1 1/4" into concrete or masonry at each location with a 2 1/2" min. from edge distance. Use (2) - #8 PFH fasteners through masonry strap into frame. For concrete (min. fc = 3000 psi) or masonry substrate (CMU shall adhere to ASTM C90).
3. Install corrosion resistant (2) - 1/4"x 3" Tapcon screws through each hinge into rough opening.
4. Host structure (wood buck, masonry, steel) to be designed and anchored to properly transfer all loads to the structure. The host structure is the responsibility of the architect or engineer of record for the project of installation.

General Notes:

1. The product shown herein is designed, tested and manufactured to comply with the wind load criteria of the adopted International Building Code (IBC), the International Residential Code (IRC), the current Florida Building Code (FBC) and the industry requirement for the stated conditions.
2. All glazing shall conform to ASTM E1300.
3. At minimum, glazing shall be 3.1mm annealed - 13.7mm airspace - 3.1mm annealed - 2.3mm PVB Interlayer by Kurraray - 3.1mm annealed glass.
4. Use structural or composite shims where required.
5. Masonry strap specifications: 20 Ga. galvanized steel, .036" min. thickness x 1.5" min. width.

This schedule addresses only the fasteners required to anchor the unit to achieve the rated design pressure and impact performance (where applicable) up to the size limitations noted. It is not intended as a guide to the installation process and does not address the sealing consideration that may arise in different wall conditions. For the complete installation procedure, see the instructions packaged with the unit or go to www.jeld-wen.com.

DISCLAIMER:

This drawing and its contents are confidential and are not to be reproduced or copied in whole or in part or used or disclosed to others except as authorized by JELD-WEN Inc.



Michael D. Stremmel
2024.03.22 06:56:38 -0400'

MICHAEL D. STREMMEL, P.E.
Florida P.E. No. 65868, REG. No. 37122
1410 Eden Road
York, PA. 17406
(717) 916-6300

This item has been digitally signed and sealed by Michael D. Stremmel, PE on the date adjacent to the seal. Printed copies of this document are not considered signed and sealed and the signature must be verified on any electronic copies.

DATE: 09/15/2023	3737 LAKEPORT BLVD. KLAMATH FALLS OR, 97601 PHONE: (800) 535-3936
DRAWN BY: M.HAM	SCALE: NTS
CHECKED BY: D.Vezo	TITLE: Contours Steel Wood Edge Outswing Glazed XX
APPROVED BY: D.Vezo	RECORD No.: D1000368
REPORT No.: NCTL-210-3195-1	CAD DWG. No.: —
REV: C	SHEET 9 of 10

MASONRY STRAP INSTALLATION

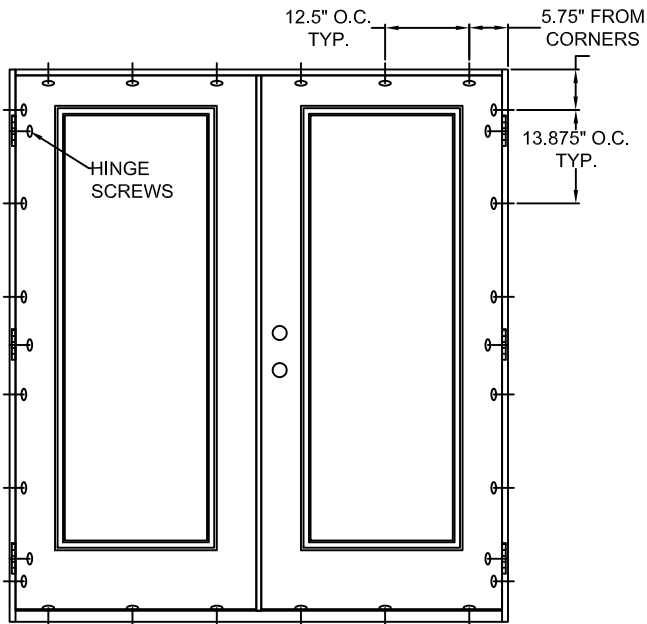

TYPICAL ELEVATION WITH FASTENER SPACING

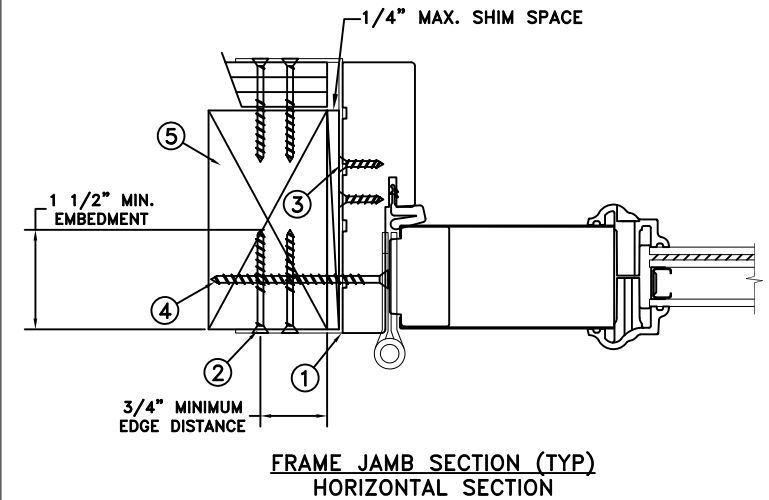
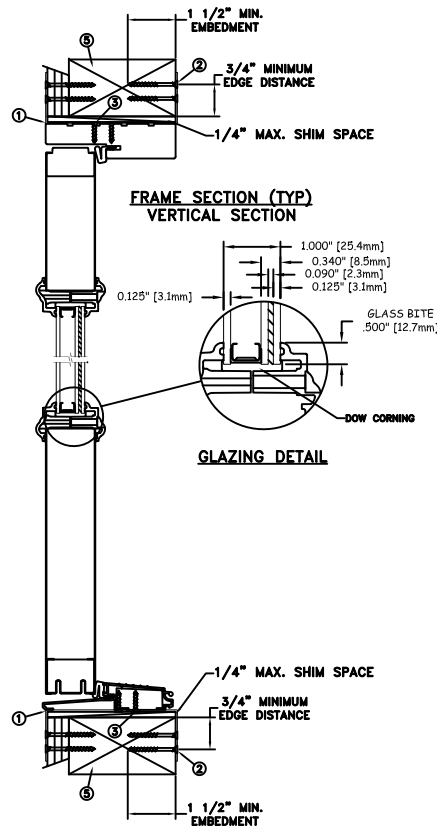

MAXIMUM FRAME	DP	IMPACT
74 x 82	+65/-60	YES

Installation Notes:

1. Seal flange/frame to substrate. Sill shall be set on a continuous serpentine bead of structural grade silicone caulk when no fastener is used to anchor the sill (typical).
2. Use min. 2 - #8 PFH or larger fasteners through masonry strap with sufficient length to penetrate a minimum of 1 1/2" into the buck. Bend straps around both sides of the buck. For 2x wood frame substrate (min. S.G. = 0.42).
3. Use min. 2 - #8 PFH or larger fasteners through masonry strap into jamb without penetrating through the jamb into product causing visibility or collateral damage to product.
4. Install corrosion resistant (2)- 1/4"x 3" Tapcon screws through each hinge into rough opening.
5. Host structure (wood buck, masonry, steel) to be designed and anchored to properly transfer all loads to the structure. The host structure is the responsibility of the architect or engineer of record for the project of installation.

General Notes:

1. The product shown herein is designed, tested and manufactured to comply with the wind load criteria of the adopted International Building Code (IBC), the International Residential Code (IRC), the current Florida Building Code (FBC) and the industry requirement for the stated conditions.
2. All glazing shall conform to ASTM E1300.
3. At minimum, glazing shall be 3.1mm annealed - 13.7mm airspace - 3.1mm annealed - 2.3mm PVB Interlayer by Kurraray - 3.1mm annealed glass.
4. Use structural or composite shims where required.
5. Masonry strap specifications: 20 Ga. galvanized steel, .036" min. thickness x 1.5" min. width.

This schedule addresses only the fasteners required to anchor the unit to achieve the rated design pressure and impact performance (where applicable) up to the size limitations noted. It is not intended as a guide to the installation process and does not address the sealing consideration that may arise in different wall conditions. For the complete installation procedure, see the instructions packaged with the unit or go to www.jeld-wen.com.

DISCLAIMER:

This drawing and its contents are confidential and are not to be reproduced or copied in whole or in part or used or disclosed to others except as authorized by JELD-WEN Inc.



This item has been digitally signed and sealed by Michael D. Stremmel, PE on the date adjacent to the seal. Printed copies of this document are not considered signed and sealed and the signature must be verified on any electronic copies.

Michael D. Stremmel
2024.03.22 06:56:38 -0400'

MICHAEL D. STREMMEL, P.E.
Florida P.E. No. 65868, REG. No. 37122
1410 Eden Road
York, PA 17406
(717) 916-6300

DATE: 09/15/2023	3737 LAKEPORT BLVD. KLAMATH FALLS OR, 97601 PHONE: (800) 535-3936
DRAWN BY: M.HAM	SCALE: NTS
CHECKED BY: D.Vezo	TITLE: Contours Steel Wood Edge Outswing Glazed XX
APPROVED BY: D.Vezo	RECORD No.: D1000368
REPORT No.: NCTL-210-3195-1	CAD DWG. No.: —
REV: C	SHEET: 10 of 10